



The type 2270 is a rugged, high performance ultrasonic level measurement sensor, having transducer and processing electronics incorporated in one single housing. It provides all the sophisticated echo detection features of the well accepted 2260 Ultrasonic Level Transmitters.

For single and multiple tank applications 2-wire sensors are recommended using either HART protocol or 4 to 20 mA for the direct communication with a panel mount controller or a PLC.

Either for liquid level measurement in sumps or tanks, for tank contents measurement, or open channel flow measurement, the 2270 Level Sensors provide the answer. Sensing ranges up to 6 m (19.7 ft) are available. PP and PVDF sensor bodies provide best chemical resistance in applications where concentrated chemical shall be detected.

## Features

- 2 wire compact sensor
- Non-contact level measuring
- Narrow 5° beam angle
- Level, volume and open channel flow
- Compact housing
- 32 points of linearization
- Fully temperature compensated electronics
- Outstanding signal processing software providing highly accurate measuring results
- PP or PVDF sensor body provides best chemical resistance
- Secondary lightning protection
- 4 to 20 mA / HART interface



## Applications

- River water
- Seawater
- Potable water
- Demineralized water
- Treated water



## Specifications (Type 2270-X-XX-4)

General	
Range	0.2 to 4 m / 0.65 to 13 ft
Total Beam Angle	6°
Measuring Frequency	80 kHz
Accuracy *	± (0.2 % of measured distance plus 0.05 % of range)
Resolution	<2 m (6.6 ft): 1 mm (0.04 in.), 2 to 4 m (6.6 to 13.1 ft): 2 mm (0.08 in.)
Environmental	
Process Temperature	-30 °C to +90 °C (-22 °F to +194°F)
Ambient Temperature	-30 °C to +80 °C (-22 °F to +176°F)
Process Pressure (absolute)	0.05 to 0.3 MPa (0.5 to 3 bar) 7.25 psi to 43.5 psi
Enclosure	
Enclosure and Sensor Material	PP or PVDF
Cable Material	Cable sealing: EPDM, cable isolation: PVC
Ingress Protection	IP68 / NEMA 6P
Process Connection	1½" BSP / NPT
Sealing	
PP sensor	EPDM
PVDF sensor	FPM (Viton)
Electrical	
Outputs	2-wire 4–20 mA , max. 600 Ohm; HART interface, Rt >= 250 Ohm
Power Supply	DC 12 to 36 V
Power Consumption	max. 720 mW, overload protected
Connecting	6 x 0,5 mm <sup>2</sup> shielded cable; Ø 6 mm x 5 m (30 m max.)
Electric shock protection	Class III, low voltage
Standard and Approvals	
General Approvals	CE

\* Under optimal circumstances of reflection and stabilized transducer temperature

## Dimensions

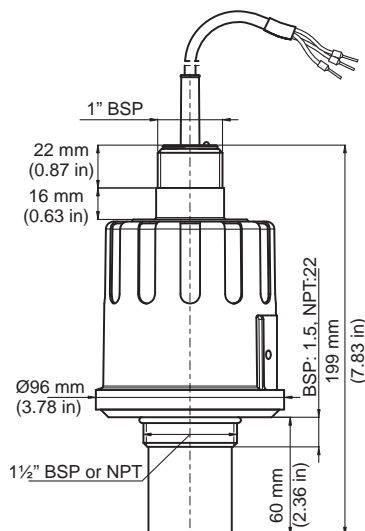

## Specifications (Type 2270-X-XX-6 / 2270-X-XX-8)

General		
Type	2270-X-XX-6	2270-X-XX-8
Range	0.25 to 6 m / 0.82 to 20 ft	0.35 to 8 m
Total Beam Angle	5°	7°
Measuring Frequency	80 kHz	50 kHz
Accuracy *	± (0.2 % of measured distance plus 0.05 % of range)	
Resolution	<2 m (6.6 ft): 1 mm (0.04 in.); 2 to 5 m (6.6 to 16.4 ft): 2 mm (0.08 in.); 6 m (19.7): 5 mm (0.2 in.)	
Environmental		
Process Temperature	-30 °C to +90 °C (-22 °F to +194 °F)	
Ambient Temperature	-30 °C to +80 °C (-22 °F to +176 °F)	
Process Pressure (absolute)	0.05 to 0.3 MPa (0.5 to 3 bar) 7.25 psi to 43.5 psi	
Enclosure		
Enclosure and Sensor Material	PP or PVDF	
Cable Material	Cable sealing: EPDM, cable isolation: PVC	
Ingress Protection	IP68 / NEMA 6P	
Process Connection	2" BSP / NPT	
Sealing		
	PP sensor	EPDM
	PVDF sensor	FPM (Viton)
Electrical		
Outputs	2-wire 4–20 mA , max. 600 Ohm; HART interface, Rt >= 250 Ohm	
Power Supply	DC 12 to 36 V	
Power Consumption	max. 720 mW, overload protected	
Connecting	6 x 0,5 mm <sup>2</sup> shielded cable; Ø 6 mm x 5 m (30 m max.)	
Electric Shock Protection	Class III, low voltage	
Standard and Approvals		
General Approvals	CE	

\* Under optimal circumstances of reflection and stabilized transducer temperature

## Dimensions

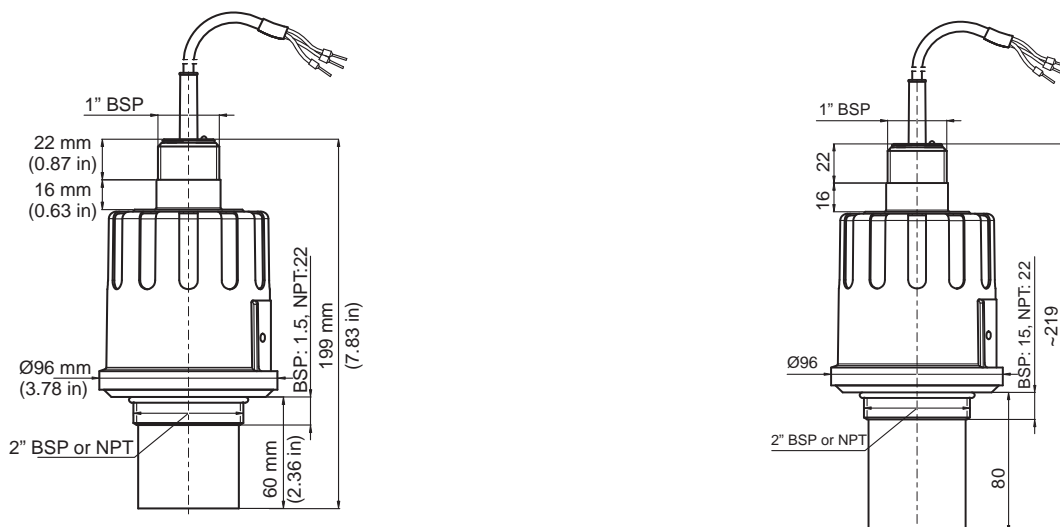

## 4 to 20 mA Loop Wiring

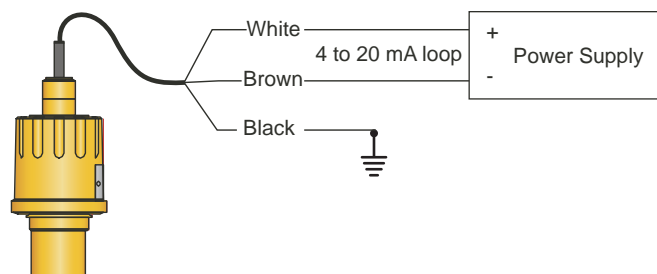

## HART Interface Wiring

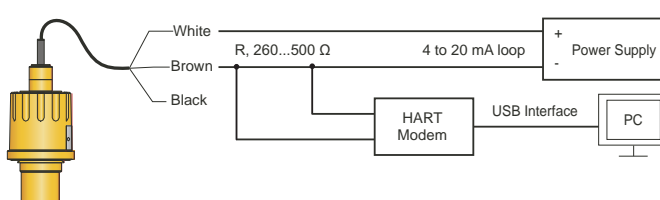

## Wiring to 9900 Universal Transmitter

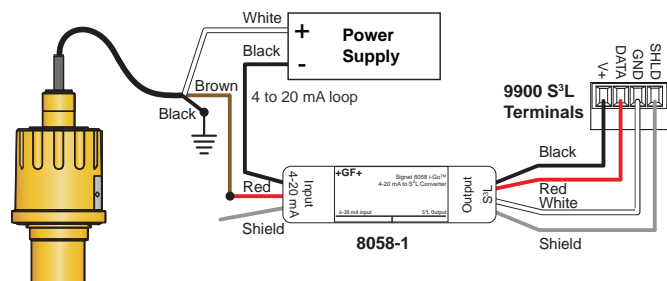

## Ordering Information



Mfr. Part No.	Code	Description
<b>Versions with NPT thread</b>		
2270-P-1N-4	<b>159 300 169</b>	Range 4 m (13.1 ft), PP body, 4 to 20 mA 2-wire/HART, NPT thread
2270-P-1N-6	<b>159 300 170</b>	Range 6 m (19.7 ft), PP body, 4 to 20 mA 2-wire/HART, NPT thread
2270-P-1N-8	<b>159 300 116</b>	Range 8 m (26.2 ft), PP body, 4 to 20 mA 2-wire/HART, NPT thread
2270-V-1N-4	<b>159 300 176</b>	Range 4 m (13.1 ft), PVDF body, 4 to 20 mA 2-wire/HART, NPT thread
2270-V-1N-6	<b>159 300 177</b>	Range 6 m (19.7 ft), PVDF body, 4 to 20 mA 2-wire/HART, NPT thread
2270-V-1N-8	<b>159 300 117</b>	Range 8 m (26.2 ft), PVDF body, 4 to 20 mA 2-wire/HART, NPT thread
<b>Versions with BSP thread</b>		
2270-P-1B-4	<b>159 300 155</b>	Range 4 m (13.1 ft), PP body, 4 to 20 mA 2-wire/HART, BSP thread
2270-P-1B-6	<b>159 300 156</b>	Range 6 m (19.7 ft), PP body, 4 to 20 mA 2-wire/HART, BSP thread
2270-P-1B-8	<b>159 300 111</b>	Range 8 m (26.2 ft), PP body, 4 to 20 mA 2-wire/HART, BSP thread
2270-V-1B-4	<b>159 300 162</b>	Range 4 m (13.1 ft), PVDF body, 4 to 20 mA 2-wire/HART, BSP thread
2270-V-1B-6	<b>159 300 163</b>	Range 6 m (19.7 ft), PVDF body, 4 to 20 mA 2-wire/HART, BSP thread
2270-V-1B-8	<b>159 300 115</b>	Range 8 m (26.2 ft), PVDF body, 4 to 20 mA 2-wire/HART, BSP thread

## Accessories

Code	Description
<b>159 300 181</b>	HART - USB Modem
<b>159 300 182</b>	HART - USB Modem, DIN Rail
<b>159 300 183</b>	HART - USB Modem, DIN Rail, ATEX